

ChurchOutlet.com

Model M1-D

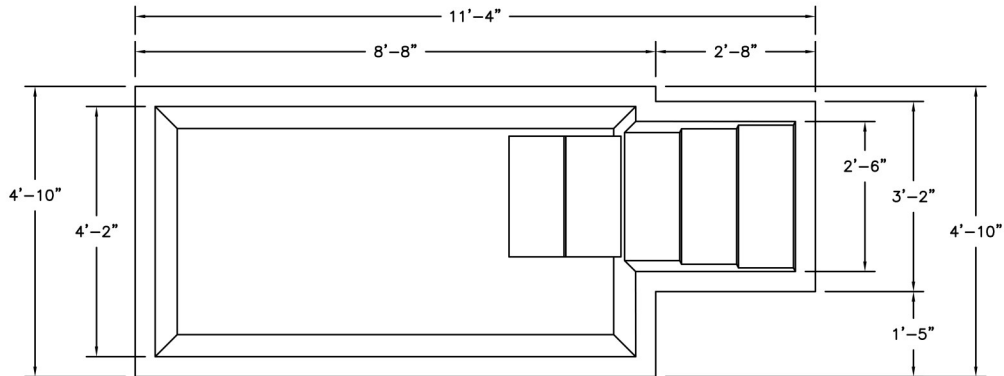

PLAN VIEW

Capacity: 750 gal.

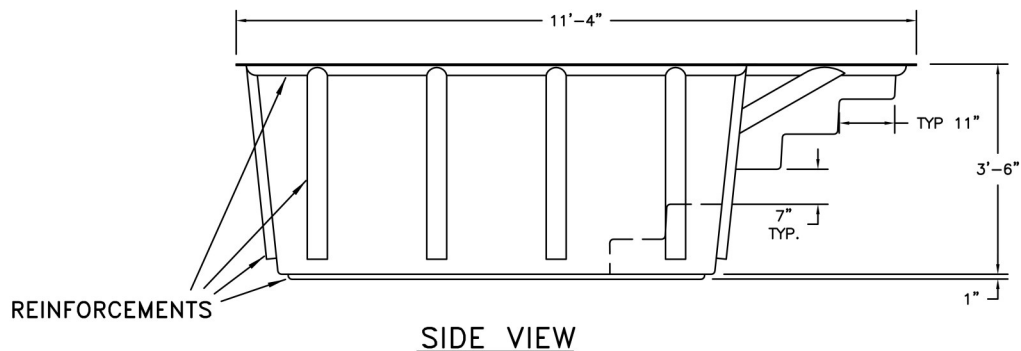

SIDE VIEW

NOTE:

STEPS SHALL CONFORM TO NATIONALLY ACCEPTED BUILDING CODE REQUIREMENTS WITH REGARD TO RISER HEIGHT AND TREAD WIDTH. STEP TREAD SURFACES SHALL HAVE A RAISED DISK SLIP-RESISTANT SURFACE. ALL CORNERS SHALL BE GENTLY ROUNDED FOR SAFETY.

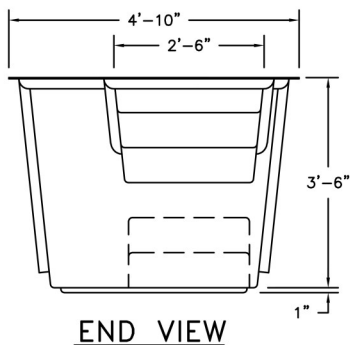

END VIEW

INSTALLATION NOTES:

PLUMBING HOLES (DRAIN, HEATER, ETC...) TO BE LOCATED AND CUT IN FIELD BY GENERAL CONTRACTOR. DRAIN SHOULD BE LOCATED IN ANY OF THE FOUR CORNERS OF THE TANK FLOOR.